

**ATZ** Extra Issue

# Motor Fan *Special Edition*

## illustrated

*The more technologies are revealed,  
the more interesting cars become.*



Special  
Feature

**Aluminum Technology 7**

# ALUMINUM

Smart Developments

# Toward the Realization of a Sustainable Mobility Society

## The Role of Aluminum

Electric vehicles are appearing one after another all over the world. The total number of electric vehicles in the world is estimated to be about 10,000,000, which includes 4,200,000 in China, followed by 3,200,000 in Europe, and 1,700,000 in the U.S. By 2030, the total number of electric vehicles is expected to reach 125,000,000. With the shift to electrification, expectations have been

increasing for high-performance aluminum for platform and battery housing structural materials. And in the context of the movement toward carbon neutrality, it's noteworthy that aluminum has excellent recycling properties. In December 2020, the European Commission published the 'Sustainable and Smart Mobility Strategy' in its 'European Green Deal Policy', stating that the challenge

facing the transport sector is to significantly reduce CO<sub>2</sub> emissions and make it sustainable. With the decarbonization of the power grid through renewable energy sources, battery recycling, innovative energy density improvements, and the replacement of rare metals, the electrification of vehicles will achieve its original purpose and become an invaluable future form of mobility.

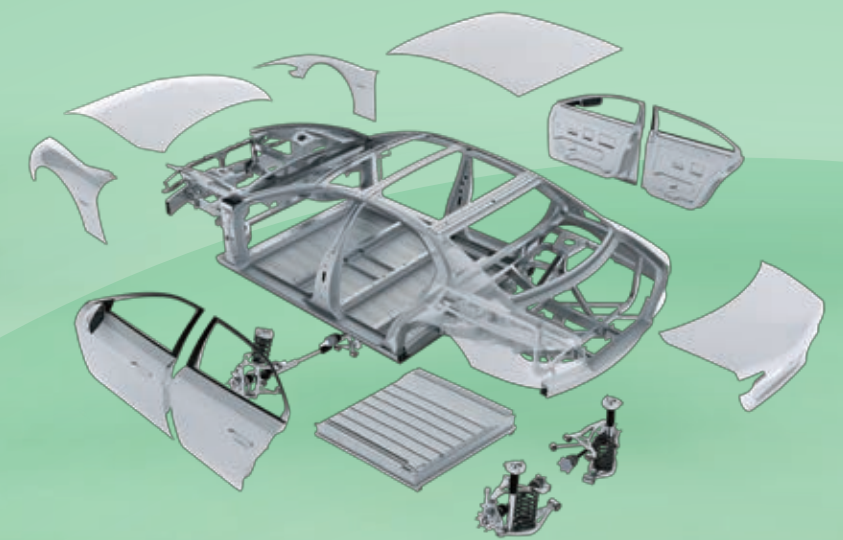
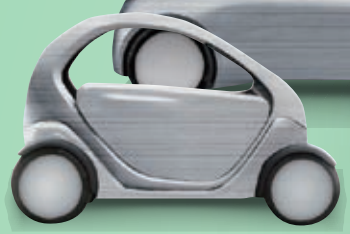
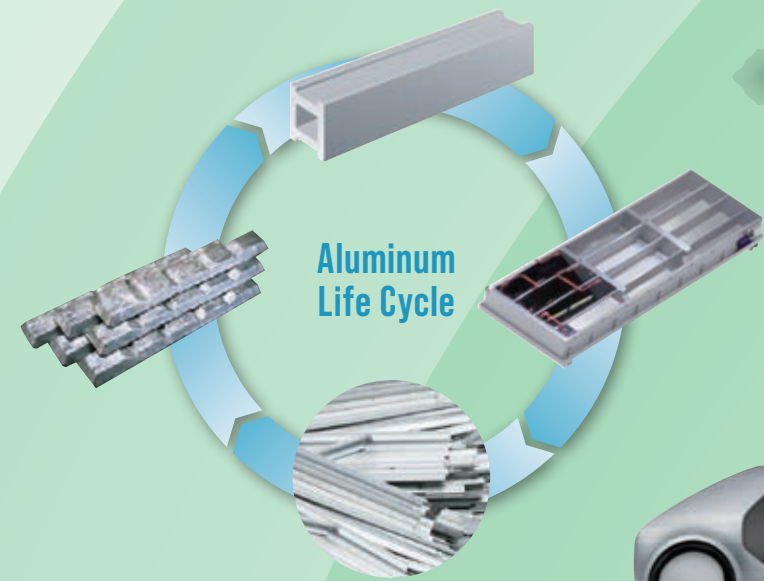

Motor For Illustrated | ALUMINIUM AUTOMOBILE TECHNOLOGY

Motor For Illustrated | ALUMINIUM AUTOMOBILE TECHNOLOGY

02

03

2025

2030

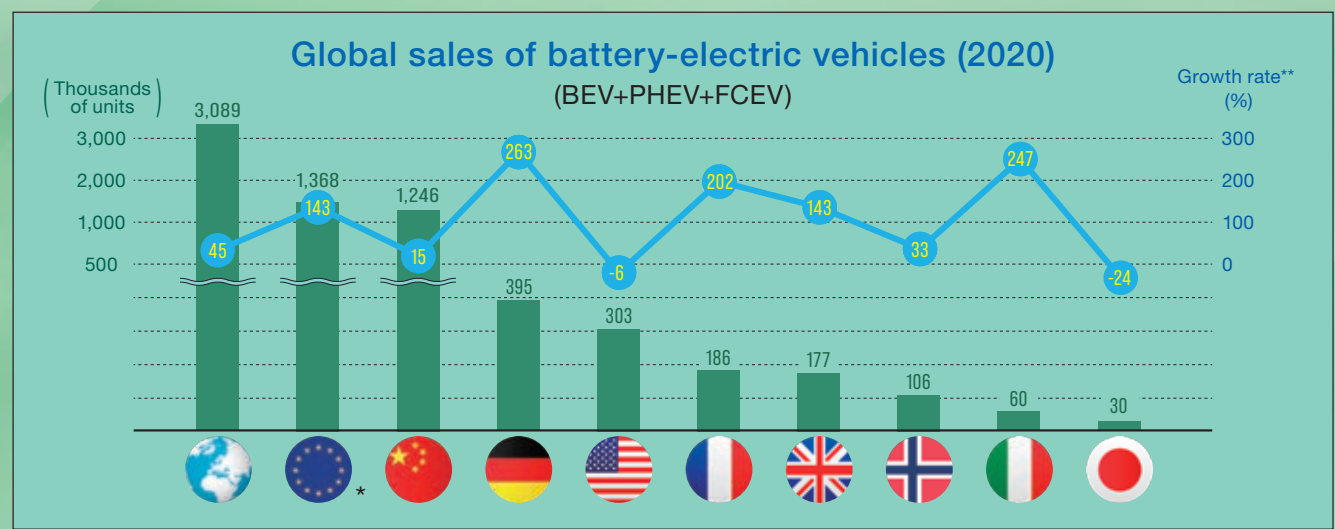

\* Europe: EU+EFTA+UK \*\* Growth rate vs. 2019  
Source: German Association of the Automotive Industry (VDA)

2040

2050

# Traditional automakers also shifting to electrification

One after another, traditional US automakers are accelerating their business transformation to electrification. GM has set a goal to make 40% of all its models BEVs by 2025 and 100% BEVs by 2035. It will introduce BEVs from Cadillac LYRIQ to the market in the first half of 2022. At

the same time, it has announced that it plans to build two battery plants in the US and to convert 100% of the electricity used in its US plants to renewable energy by 2035. Ford has announced 'Ford+', a strategy to invest in EV technologies and enhance connected services, with the

goal of making 40% of all of its vehicles sold worldwide EVs by 2030. The F-series of pickup trucks has a history of more than 40 years. The BEV F-150 Lightning, scheduled to be launched in the first half of 2022, symbolizes the traditional US automaker's business shift to electrification.

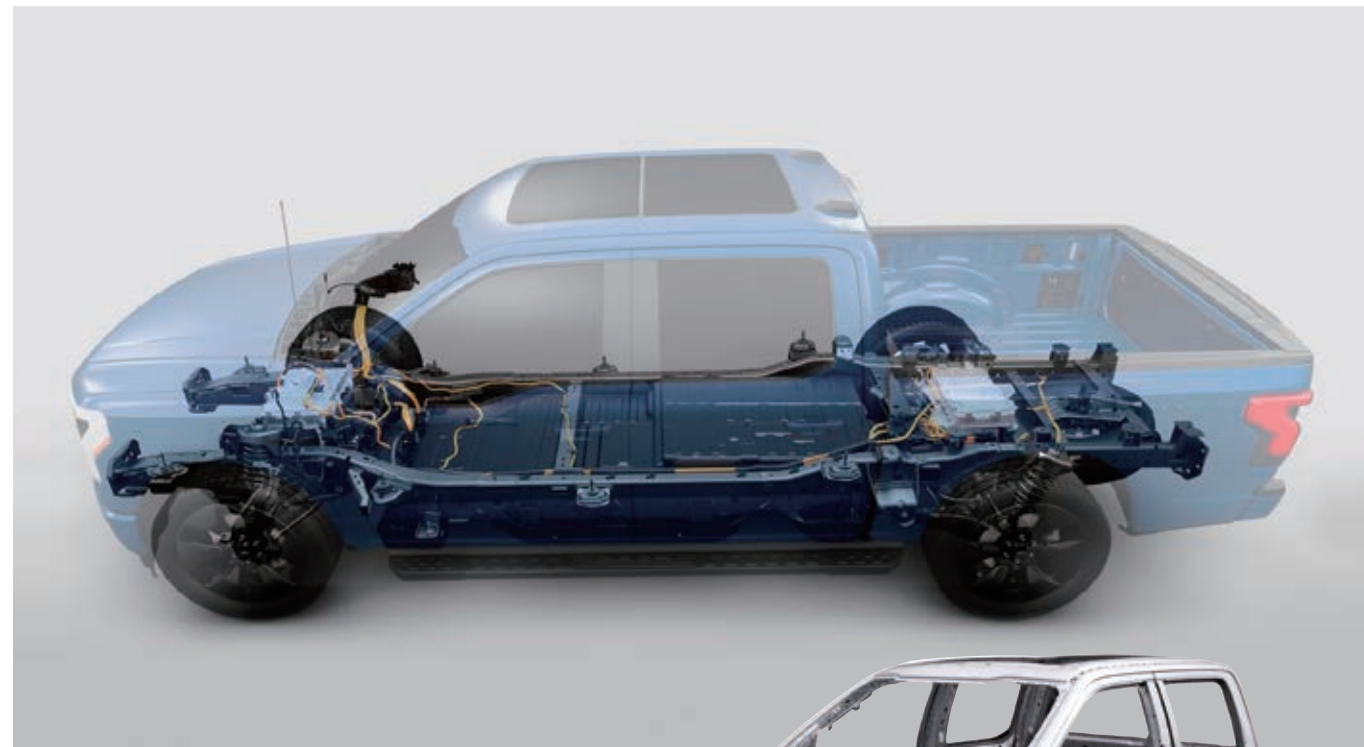

## Ford F-150 Lightning

The Ford F-150 Lightning BEV standard model pickup truck has all-wheel drive with 318kW output. The more powerful model, with 420kW output and 1,050Nm of torque, can carry 2,000 pounds (907 kilograms) of cargo and tow 10,000 pounds (4.53 tons). Two battery types are available, with a range of 230 miles (370 kilometers) and 300 miles (480 kilometers). The market launch of the second-generation F-150 Lightning, which uses the new TE1 platform, is scheduled for the end of 2025, bringing the annual production of the F-150

series close to 160,000 units. Ford was the first US automaker to use all-aluminum body panels, making a splash by reducing the weight of the F-150 by 320 kilograms. In the future, it plans to use aluminum body panels for its Super Duty full-size pickup, as well as for the Expedition and Lincoln Navigator SUVs.



F-150: aluminum body panels

## GM Cadillac LYRIQ

General Motors has introduced the Ultium, a new battery for EVs, and the Ultium platform, a next-generation EV platform. The new 'Ultium' battery allows high-capacity pouch cells to be stacked freely (horizontally, vertically, or vertically within the battery pack), thus optimizing both the battery capacity and the platform layout. Starting in 2021, GM will be introducing the Ultium platform to all its brands and launching new EVs sequentially.

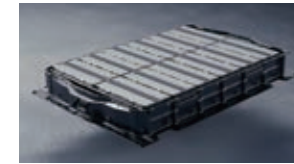

## Ford Mustang Mach-E

The Mustang Mach-E uses the GE1 (Global Electrified 1) platform developed by Ford's team of EV specialists, Team Edison. It's based on the C2 platform instead of the MEB of the Volkswagen Group. Mainly composed of pressed aluminum alloy parts and aluminum alloy extruded shapes, the battery housing measures 220 by 150 centimeters. It's assembled by state-of-the-art robotic welding, adhesive application, and mechanical



joining with self-piercing rivets. The bonnet and fenders are made of 6000-Series aluminum alloy body panels.

## GM Chevrolet Corvette C8 E-Ray

The Chevrolet Corvette C8 features an all-aluminum space frame, with high-strength extruded aluminum shapes used throughout to increase rigidity and improve performance. The previous-generation Corvette C7 had a space frame structure that emphasized the strength of the side sills, but the Corvette C8 has a larger center tunnel, serving as the backbone, to enhance the strength of the frame. The Corvette C8 platform is composed of 40% aluminum alloy extruded shapes, 39% aluminum alloy sheets, 18% aluminum castings, and 3% other materials. The hybrid Corvette C8 E-Ray reportedly combines a V8 gasoline engine with an electric powertrain in the front area, with the battery case housed in an aluminum alloy center tunnel.

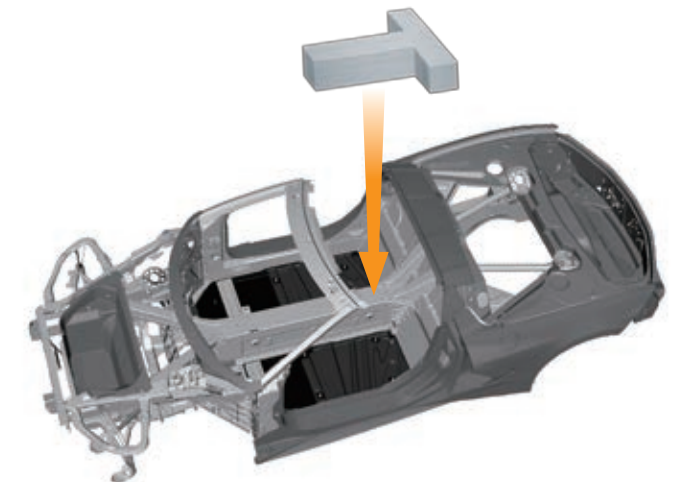

Chevrolet Corvette: aluminum space frame

## EV platform performance evolving for the future

In 2020, EURO NCAP introduced a new frontal crash test in which a mobile progressive deformable barrier is driven into the vehicle.

This frontal crash test assesses not only the protection of the vehicle occupants, but also how the front-end structure affects the injuries sustained by the colliding parties.

In the side impact test, the impact speed and mass of the moving barrier were increased. There are expectations for the revision of crash safety structures to reduce the damage to high-voltage components and batteries.

Aluminum structural members play an important role in the body structure.

The aluminum shock-absorbing components of the front end prevent wheels and other objects from entering the vehicle interior and also mitigate the impact on the occupants. The battery housing disperses impact energy and absorbs residual energy to protect the battery pack.

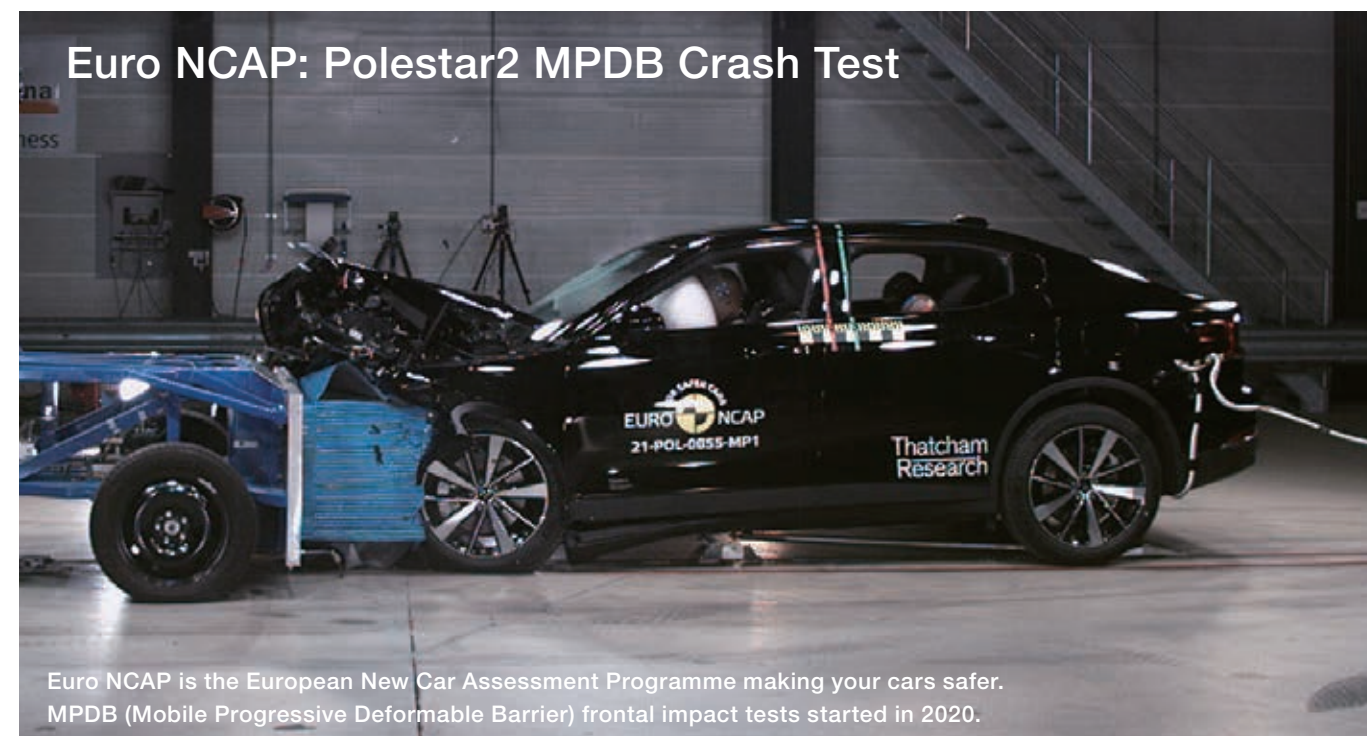

Euro NCAP: Polestar2 MPDB Crash Test

Euro NCAP is the European New Car Assessment Programme making your cars safer. MPDB (Mobile Progressive Deformable Barrier) frontal impact tests started in 2020.

### Polestar 2 CMA platform

Polestar 2 has been awarded a 5-star safety rating in the 2021 EURO NCAP tests. It uses the same Compact Modular Architecture (CMA) as the Volvo XC40. The platform is equipped with Front Lower Load Path (FLLP) and Severe Partial Offset Collision (SPOC) aluminum alloy shock-absorbing components, which enhance the function of the front-side crumple zone in the event of a frontal collision. This prevents the wheels and other components from entering the interior and further mitigates the impact on the occupants to achieve the highest level of safety. The battery pack is protected by a three-layered extruded aluminum battery case that disperses impact energy and absorbs residual energy.

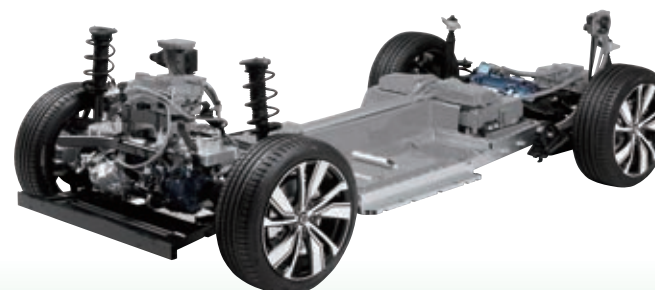

### Volkswagen ID.4 MEB

The ID.4 is an electric SUV in the compact SUV segment that uses a new generation of MEB (Modular electric drive matrix). Developed for reduced-cost mass production of BEVs, the MEB platform can be customized depending on vehicle size and other factors. The extruded aluminum alloy battery housing holds a 486kg cell module, and the cells are temperature controlled by water-cooled plates made of aluminum alloy.



### Watt Electric PACES: EV platform

The Passenger and Commercial EV Skateboard (PACES) EV platform, developed by the UK-based automaker Watt Electric Vehicles, uses an all-aluminum alloy space frame structure. The PACES platform is manufactured using an innovative bonding technology called FlexTech, which combines extruded aluminum shapes with precision laser-cut aluminum components in a single-step coating and curing process. This structure is simple and dimensionally accurate, and requires no post-assembly machining, resulting in high production efficiency and reduced manufacturing costs.

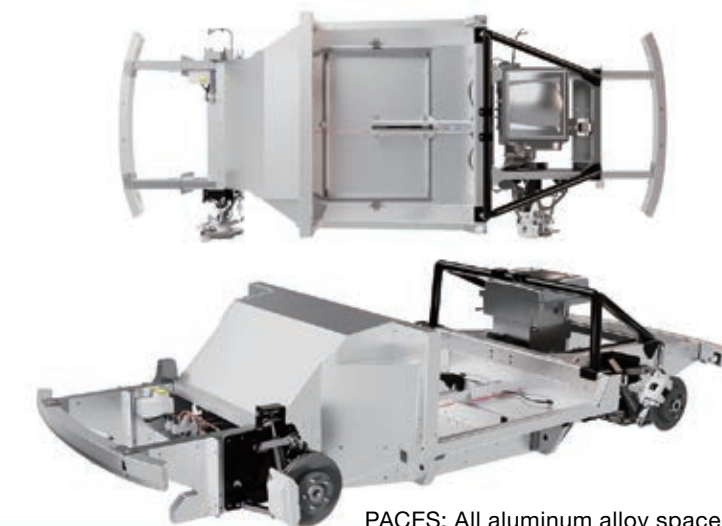

PACES: All aluminum alloy space frame

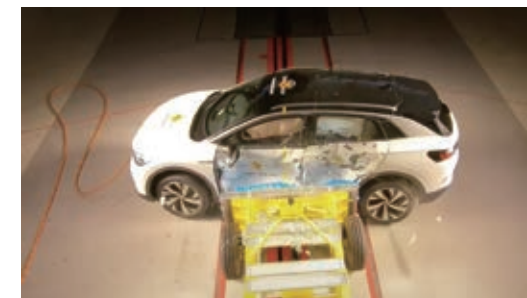

### Renault CMF-EV

The base for the Nissan Aria and Renault Mégane E is the CMF-EV platform, a lightweight and highly rigid next-generation EV platform designed by the Renault-Nissan-Mitsubishi alliance. Renault has unveiled the Mégane eVision under the concept of 'Reimagining the traditional hatchback in an emotional way' and aims to start production by the end of 2021. It incorporates into its platform a thin, flat, 11-centimeter-thick battery called Slimline. This allows for a low center of gravity, a sporty appearance, and competitive aerodynamics.



# Battery modules are the key to promoting electrification.

Today, there is a growing worldwide momentum to promote carbon neutral measures. The amount of greenhouse gases emitted during the production of electric cars is much higher than that for gasoline cars. The production of batteries is also associated with environmental problems related to the

mining of scarce mineral resources for raw materials and the environmental burden of dependence on coal-fired power generation areas. The battery is the key in terms of cruising range, charging speed, power output, and safety. Automakers are aiming to procure raw materials,

secure production bases, and establish recycling systems to achieve a sustainable supply chain. The promotion of R&D to reduce the use of rare metals and the development of a network of fast-charging stations are also essential.

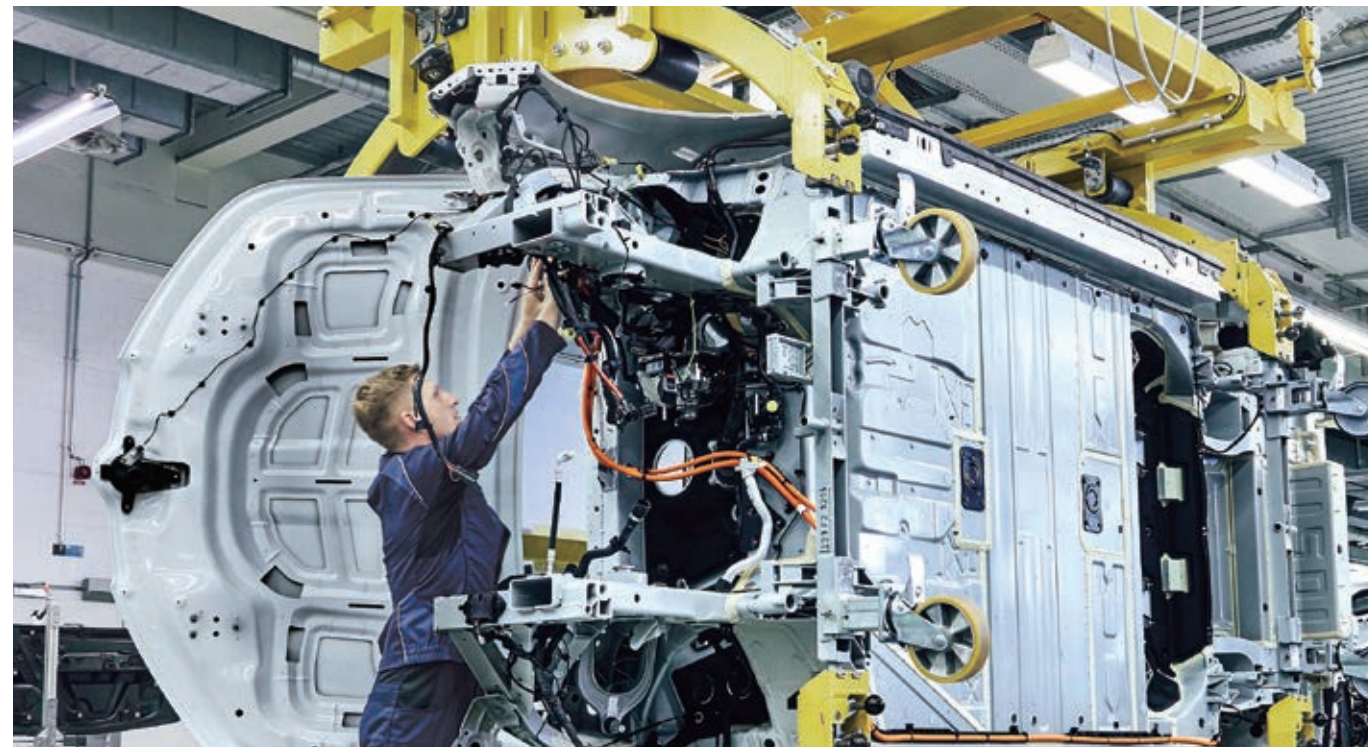

## Audi Q4 e-tron

The Audi Q4 e-tron is an EV model in the compact SUV segment that uses the MEB platform of the Volkswagen Group. The Q4 40 e-tron3 and Q4 50 e-tron quattro4 are equipped with a high-capacity battery weighing approximately 500 kilograms and with a capacity of 76.6kWh, providing a cruising range of over 450 kilometers. The 182cm x 145cm x 16cm battery housing is a solid structure made of extruded aluminum alloy with a hollow shape and weighing 100 kilograms. The cooling plate and under protection cover are also made of aluminum sheets.

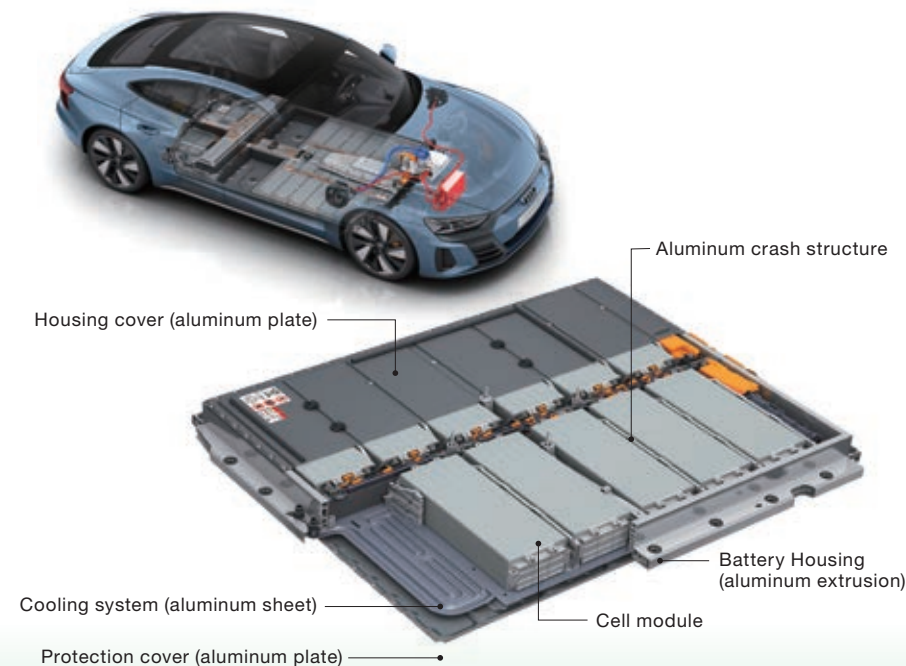

## BMW iX

The BMW iX is an advanced platform structure based on an aluminum alloy space frame, with the roof, as well as the side and rear members, made of CFRTF. The lightweight and highly rigid aluminum alloy frame is combined with soft-impact and damage-resistant CFRTF members to enhance crash safety. Constructed from welded aluminum alloy extruded hollow shapes, the battery housing supports a huge battery capacity of 105.2kWh. The cooling plate and housing cover are made of aluminum sheets.

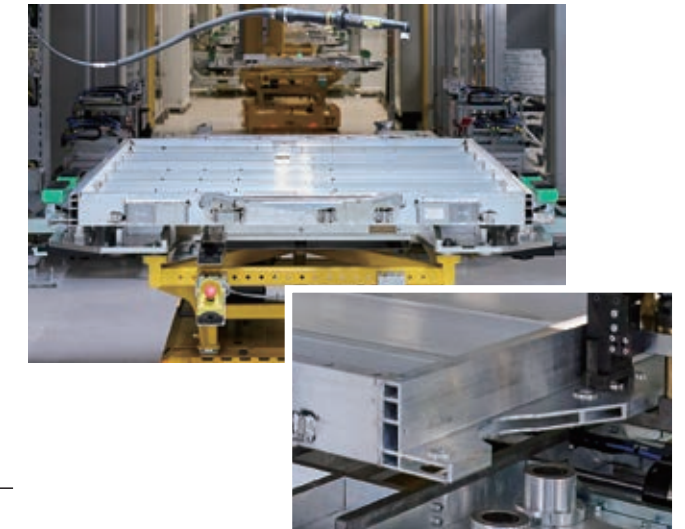
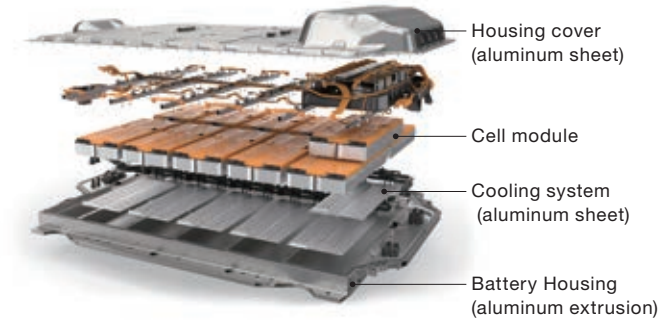
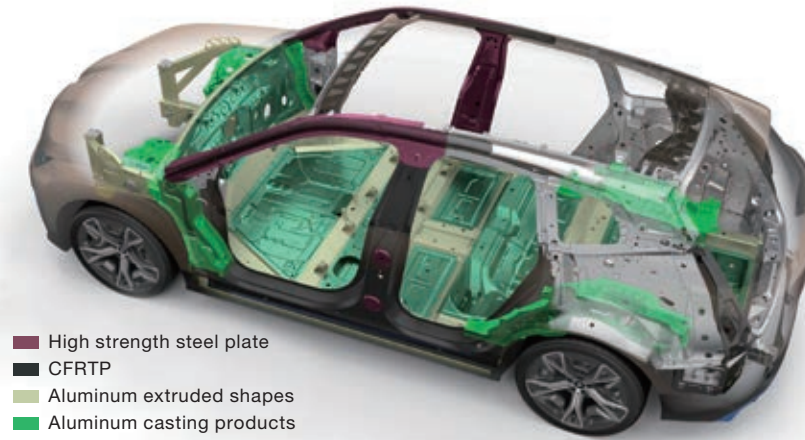

## Mercedes-Benz EQ

The EQS with the Daimler-developed MEA has been unveiled. The EQS lithium-ion battery features the latest generation of NCM811 cells (main raw material content of the cathode material: 8 nickel; 1 cobalt; 1 manganese), which use less than 10% cobalt.

The EQS is powered by a 108kWh battery with a cruising range of up to 770 kilometers. The battery housing, made of extruded aluminum alloy with excellent shock absorption and thermal conductivity, includes a liquid cooling system for preheating and cooling.



Mercedes-Benz EQC Side impact protection structure (aluminum extrusion)

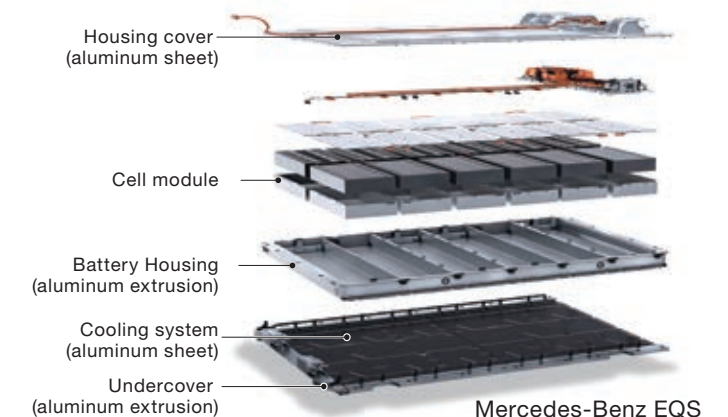

Mercedes-Benz EQS

# Hydrogen highlighted as the next clean energy source

Hydrogen can be produced with virtually no CO<sub>2</sub> emissions. It all depends on which of the two production methods is used: 'Green Hydrogen' using electrolysis from renewable energy sources; or 'Blue Hydrogen' using CCS from natural gas. It's not easy to produce hydrogen

using renewable energy, but according to CCS and CCUS, low-carbon hydrogen can be achieved even if electricity from fossil fuels is used. According to the 'European Hydrogen Roadmap', approx. 45 million passenger cars, 6.5 million LCVs, 250,000 buses, and 1.7 million trucks,

or 20-25% of each segment, will be hydrogen fuel cell vehicles by 2050. In the case of the ratio for larger vehicles with long-range requirements, an ambitious scenario has also been drawn up, in which it would be 30% for large cars and vans and 55% for taxis.

CCS (Carbon dioxide Capture and Storage) , CCUS (Carbon dioxide Capture, Utilization and Storage)

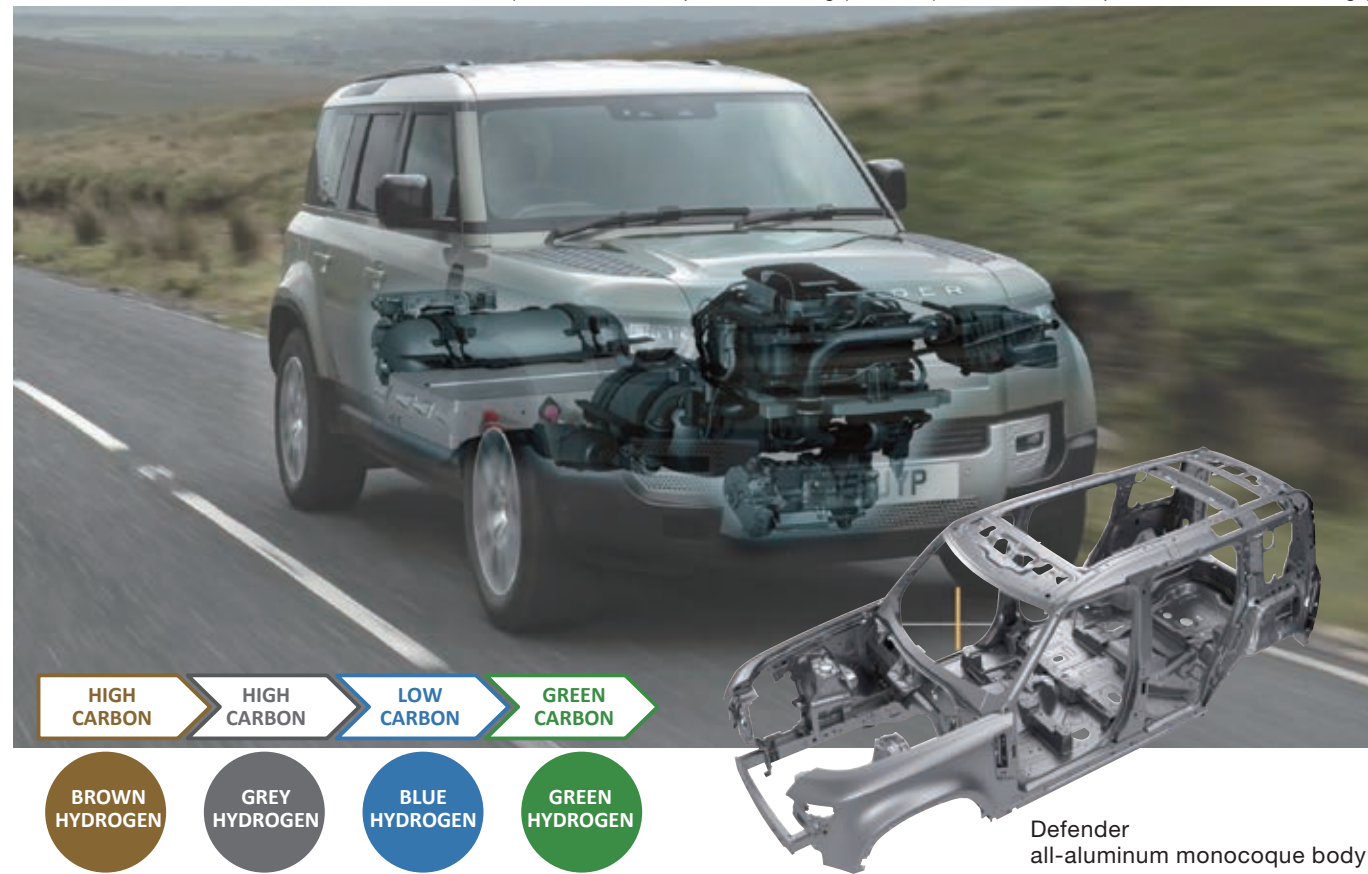

Defender all-aluminum monocoque body

## Land rover Defender(FCEV)

The Land Rover Defender made a splash at IAA Cars 2019 with the announcement of its aluminum alloy monocoque body. The Defender's suspension, subframe and other structural components make extensive use of forged aluminum components and extruded aluminum components. The Defender FCEV, a prototype hydrogen fuel cell SUV based on the Defender, is ideal for heavy-duty vehicles that travel long distances due to its high energy efficiency and quick refueling with hydrogen.

Photo: © Jaguar Land Rover

## HYDROGEN TECHNOLOGY EXISTS AND IS READY FOR DEPLOYMENT

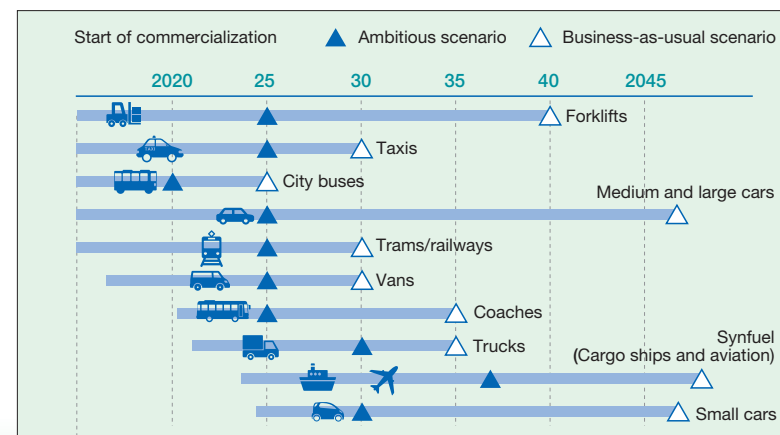

Source: HYDROGEN ROADMAP EUROPE © Fuel Cells and Hydrogen Joint Undertaking

## Citroen e jumpy hydrogen

Stellantis has unveiled the Citroen e-Jumpy Hydrogen, a mid-sized FCEV van with plug-in capability. Powered by a 45kW fuel cell system with 4.4 kilograms of hydrogen stored in three 700 bar (70MPa) tanks, a 10.5kWh battery, and a 100kW motor with front-wheel drive, it has a cruising range of 400 kilometers. The Peugeot e-Expert Hydrogen and Opel Vivaro-e Hydrogen are sister vehicles.



## TOYOTA CaetanoBus

Toyota Motor Europe is strengthening its cooperation with Portugal's CaetanoBus in the manufacture of zero-emission buses. Since 2019, Toyota has been providing fuel cell technology, including key components such as FC stacks and high-pressure hydrogen tanks, for its H2.City Gold fuel cell city bus. With a proven track record in the development and manufacture of electric buses, Caetano Bus is increasing its presence by rapidly increasing sales of zero-emission buses right across Europe.

## TOYOTA MIRAI

TOYOTA's new MIRAI is an FCEV based on the GA-L platform of the Toyota New Global Architecture (TNGA). The weight of the FC stack has been halved from the previous model, and the entire fuel cell system is placed in the front. The battery and motor are placed in the rear to provide rear-wheel drive, resulting in a 50:50 weight distribution and a low center of gravity. It has a cruising range of 650 kilometers (European specifications).



## Fuel Cell trucks & commercial vehicles

In the field of long-haul transport trucks, represented by Daimler, Traitung, and MAN, there is now

global competition for automated driving and electrification technologies, with many

manufacturers focusing on hydrogen fuel cells for electrification. Emerging manufacturers such as Hizon Motors have also joined the competition. In 2020, Daimler Truck announced its liquid hydrogen-powered Mercedes-Benz GenH2 truck, which aims to achieve a range of more than 1,000 kilometers without refueling. It plans to test it on public roads in 2021, conduct user demonstrations from 2023, and market it in 2027.



Daimler Fuel Cell Truck



Hyzon Motors Fuel Cell Truck

Photo: © Stellantis/ © TOYOTA/ © CaetanoBus/ © Daimler/ © Hyzon motors

# Benefits of aluminum closed-loop recycling

Aluminum is helping to achieve 'sustainable mobility' by improving fuel efficiency and reducing CO<sub>2</sub> emissions, but it is also contributing to reducing environmental impact in the vehicle manufacturing process. It is the closed-loop recycling of materials that is attracting the most attention today.

The 'aluminum closed loop' is a system in which the scrap material from the production of aluminum sheets for body panels is returned to the supplier, who then manufactures aluminum coil again and delivers it to the manufacturer. Audi has reduced CO<sub>2</sub> emissions by

several thousand tons per year at one of its production sites in Germany. Similar efforts are being made by other automakers. In Japan, UACJ is promoting sustainability throughout the supply chain by supplying aluminum body panel materials to Toyota Land Cruiser, Nissan Rogue, etc.

## Aluminum closed-loop recycling system

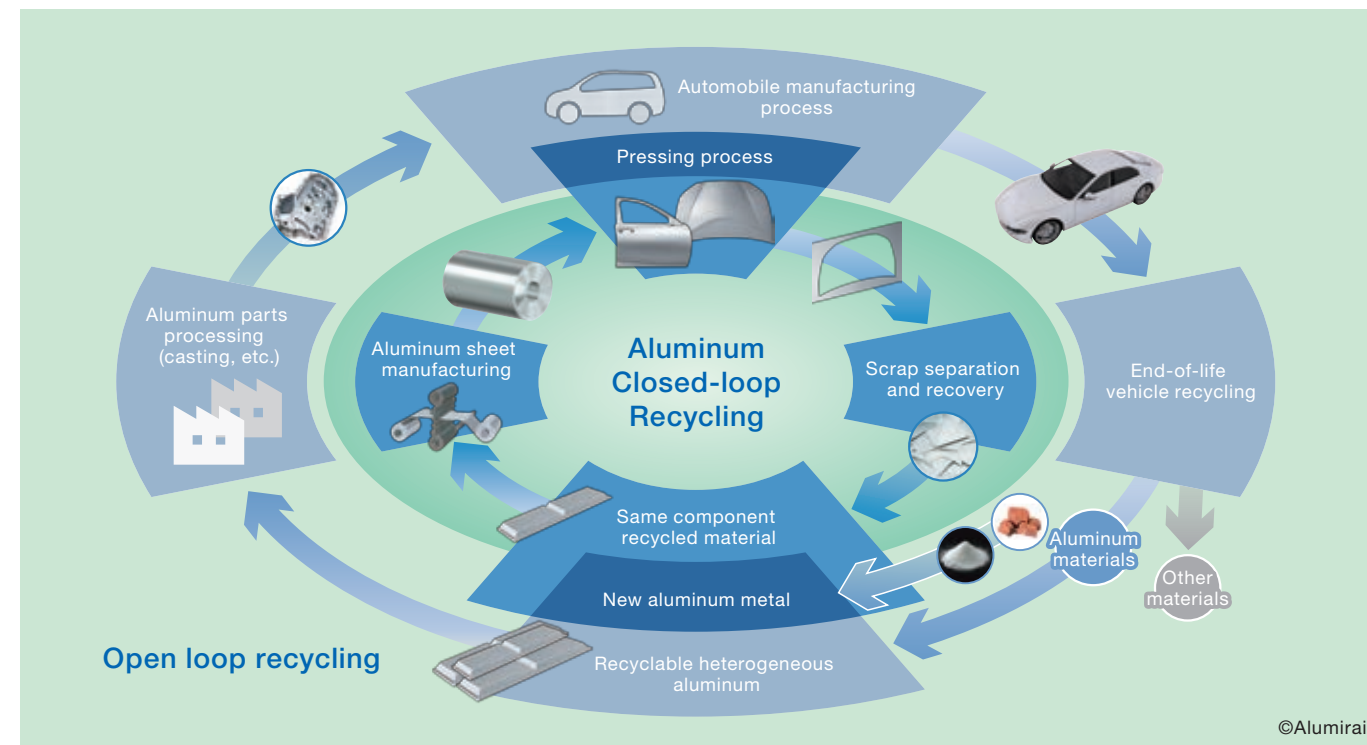

## NISSAN Qashqai

The new Qashqai, a crossover SUV based on Renault-Nissan's CMF-C platform, will also feature e-Power. It has aluminum body panels, and the aluminum sheet material is used in a cyclical manner via 'Nissan's Aluminum Closed-loop Recycling System'. Nissan announced in 2021 that it will expand the solar power generation capacity of its Sunderland Plant in the UK. The plant, which has already installed ten wind turbines (6.6MW) and a solar power generation system (4.75MW), has been using renewable energy for automobile manufacturing. This time, a power generation facility (20MW) consisting of 37,000 solar panels will be added, bringing the total power generation capacity to 32MW. Nissan's goal is to achieve carbon neutrality throughout the entire life cycle of its vehicle manufacturing and products by 2050.



Solar panels at Nissan's Sunderland plant (UK)

# Aluminum components enhance vehicle performance

## Aluminum Alloy Sheets for Body Panels

The use of aluminum alloy sheets for body panels is an effective means of reducing weight and improving cruising range. The mainstream material used for body panels, 6000-Series aluminum alloy, features good formability when pressed, but low strength. However, this strength is greatly improved by the baking coating process.



Braking durability test status: ENDLESS ADVANCE Co., Ltd. (Japan)

## Forged aluminum alloy brake calipers

UACJ creates forged brake calipers using its high-strength aluminum alloy at high temperatures. The demand for lightweight, high-rigidity forged aluminum parts is expanding for SUVs and other vehicle bodies due to their growing size and higher performance. In addition to forgeability, forging aluminum alloys have been developed to meet required characteristics, such as high strength, high wear resistance, and high temperature strength.

## Various aluminum alloy extruded shapes

The aluminum extrusion process can form complex cross-sectional shapes, making it ideal for components with a constant cross-sectional shape and long length, such as bumper beams. Aluminum extruded shapes with a hollow cross-section are used in battery housings and space frame structures, while braces use aluminum extruded shapes with a solid cross-section. As shown in the diagram at bottom right, aluminum extruded shapes are characterized by their ability for fitting: they can be joined tightly by fitting the inward and outward end projections.



Aluminum extruded shapes in bumper beams and crash boxes (UACJ Corporation)



Aluminum alloy extruded shapes (various types of braces)

## Joining technique of aluminum extruded shapes by fitting

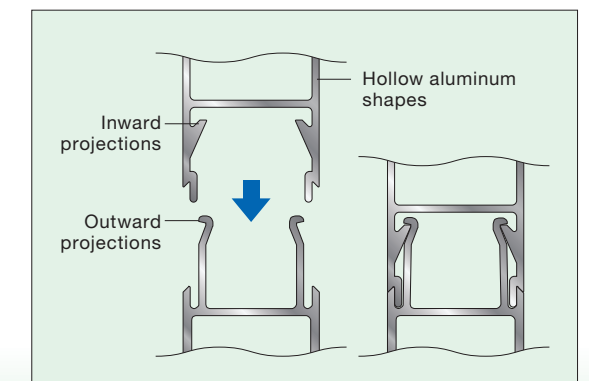

# UACJ established its Mobility Technology Center

Aluminum has been widely adopted as a structural material for automobiles because of its light weight, and it is also an essential structural material for future mobility development. UACJ Corporation, one of the world's leading comprehensive aluminum manufacturers, established its Automotive Parts Business Division in February 2019 to further strengthen its automotive aluminum materials business by bringing together the aluminum materials technology and expertise cultivated over many years.

In addition, in October 2020, with the aim of developing advanced aluminum auto parts through an integrated development and design system, the company opened its Mobility Technology Center (MTC) adjacent to its R&D Center in Nagoya, Aichi Prefecture. One year since its establishment, Motor Fan illustrated conducted an interview with Yoichiro Kohiyama, the head of MTC, and Naoki Tokizane, the Senior Principal Manager.

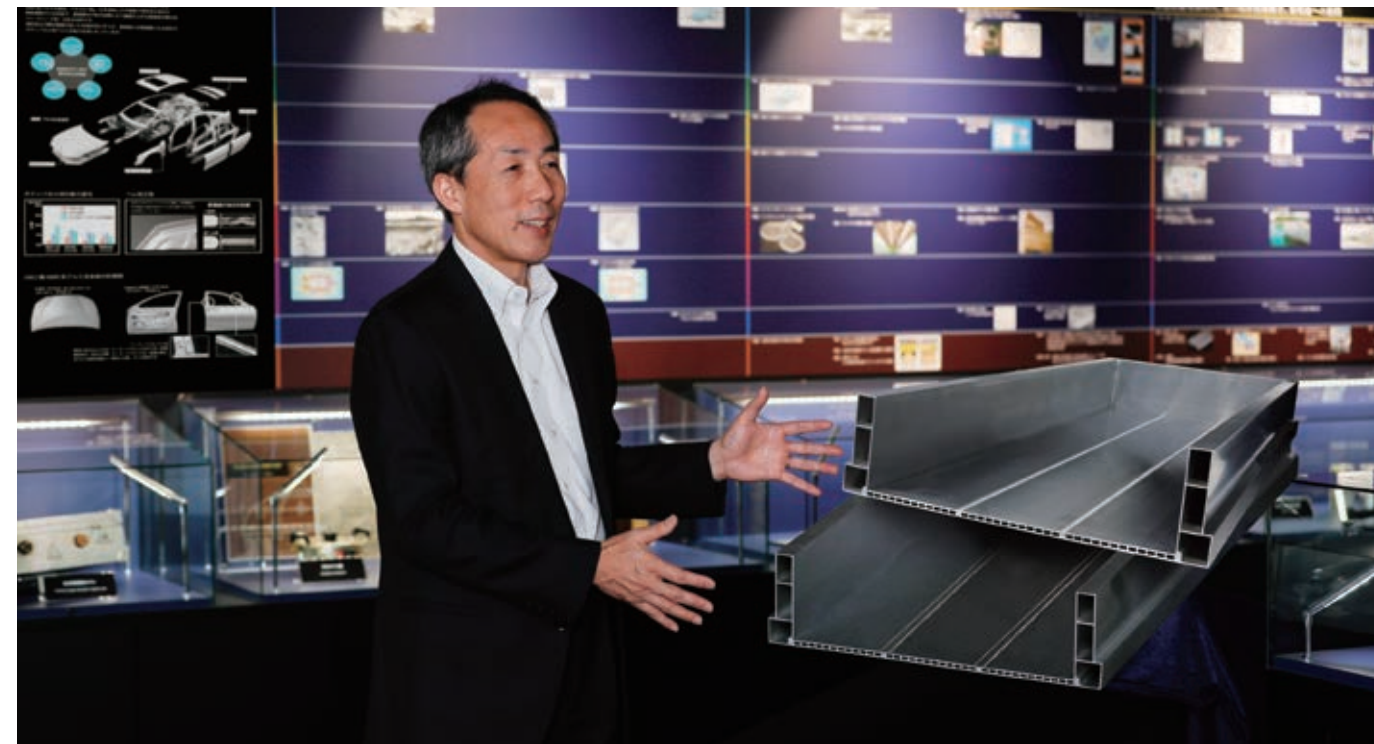

**Q: How does MTC differ from conventional R&D departments?**

**Kohiyama:** MTC is a department with an integrated system that handles everything from technical research and technology planning to material development, product development, advanced development, and production technology development. For basic and elemental technologies, we work with the UACJ R&D Center to demonstrate our comprehensive capabilities in the development of aluminum components.

**Q: Can you give us specific examples of aluminum components?**

**Kohiyama:** MTC is promoting the development of structural parts for

automobiles and components for next-generation mobility. We have jointly developed bumpers and body structural parts with automakers and mass-produced them.

**Q: What kind of image do you have for advanced aluminum parts?**

**Kohiyama:** MTC has started to develop composite structures with CFRP and steel. For advanced development, we are engaged in co-creation innovation activities with the UACJ R&D Center, companies from different industries, universities, and public institutions.

**Q: What characteristics will be required of aluminum parts in the future?**

**Kohiyama:** One of the greatest

advantages of using aluminum is its recyclability. We're focusing on the development of aluminum recycling materials and aluminum manufacturing processes with reduced environmental impact. Aluminum components will greatly contribute to the realization of a sustainable mobility society.

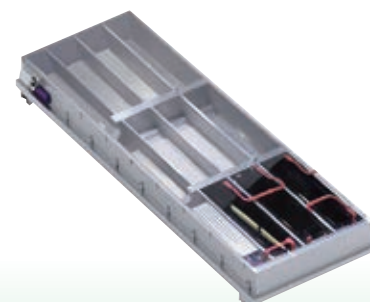

## A core center for next-generation mobility parts

**Q: As demand for aluminum members rapidly increases, how do you see your future prospects?**

**Tokizane:** Against the backdrop of the global decarbonization movement, emerging EV manufacturers in the U.S. are making great strides, and traditional car manufacturers also have strong needs. Aluminum structural members are manufactured at UACJ Automotive Whitehall Industries, Inc. (UWH) in Michigan and other plants in the U.S.A., and we have expanded our aluminum extrusion presses and established a new plant in Arizona. In the future, we will strengthen the production of components for battery housings and aluminum structural components for crushable zones.



**Q: What is MTC's role in overseas expansion?**

**Tokizane:** MTC is the hub of our automotive parts development and has its footprint also in U.S. The two MTCs are working together with UWH and our R&D centers (Japan, U.S., Thailand) to develop structural components and materials. In the future, we will also promote proposal-based development in China and other regions around the world. In China, we have established a joint venture, Dicastal UACJ Bolv Automotive Components Co., Ltd. (DUB), with CITIC Group Corporation Ltd.

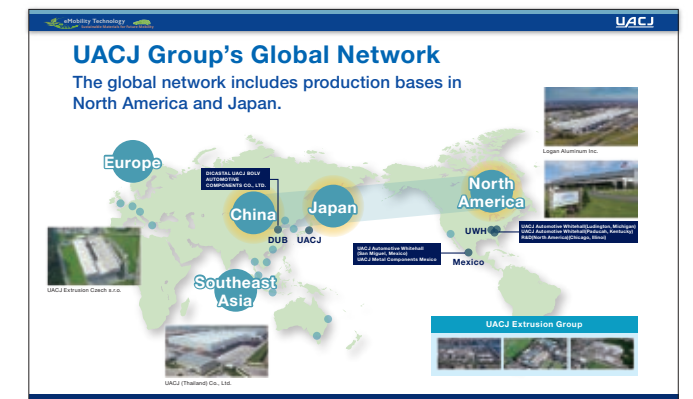

UACJ R&D Center, Mobility Technology Center



Head of Mobility Technology Center (MTC)  
Automotive Parts Business Division  
UACJ Corporation

Yoichiro KOHIYAMA



Senior Principal Manager  
Mobility Technology Center (MTC)  
Automotive Parts Business Division  
UACJ Corporation

Naoki TOKIZANE





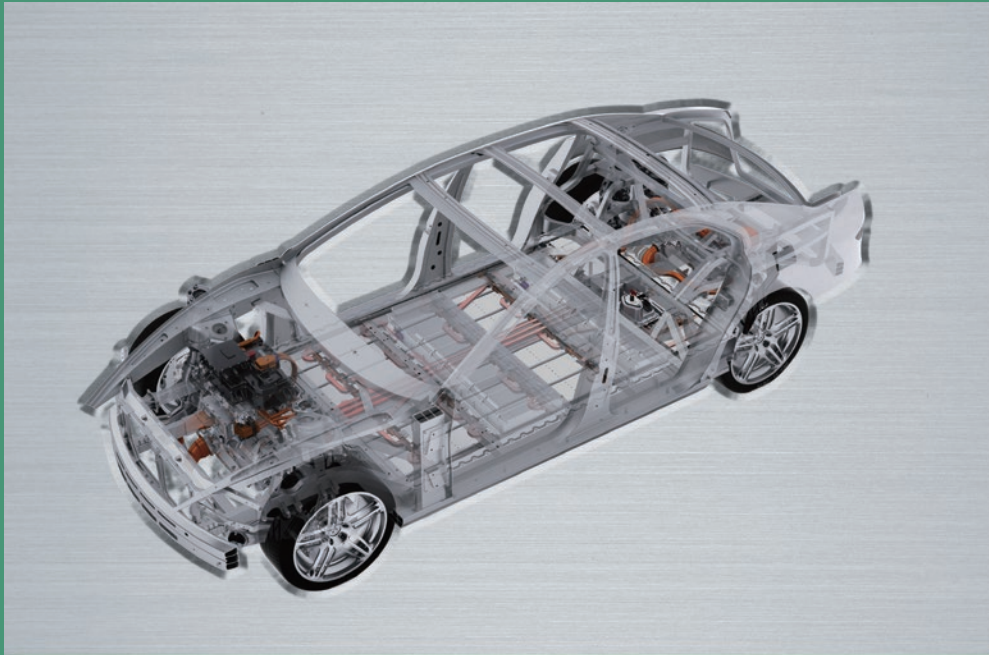

## Aluminum Material for Automobiles

The environment-friendly metal underpinning  
next-generation automobile development

### A Very Popular Japanese Magazine

BACK NUMBERS

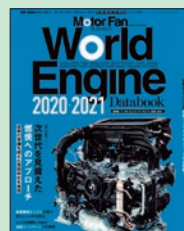

**Motor Fan**  
illustrated

Motor Fan illustrated  
Publisher: SAN'EI CORPORATION  
7F Shinjuku East Side Square, 6-27-30 Shinjuku,  
Shinjuku-ku, Tokyo 160-8461, JAPAN  
<http://motorfan-i.com>  
email: MFi@san-ei-corp.co.jp

'Motor Fan illustrated' is a very popular Japanese magazine dedicated to automotive technologies, materials, car electronics, and production processes. It is a unique publication because it presents technical information using expressive terminology, and it is also graphically beautiful, with many photographs and illustrations to enhance the understanding of the articles. As a result, many enthusiastic non-Japanese readers from all over the world enjoy reading it. Motor Fan illustrated has been published for 15 years and it is read by automotive engineers, university students, and auto enthusiasts. The editorial concept of the magazine is: 'The more technologies are revealed, the more interesting cars become.'

